

15 cm Midrange

15M/4531K00

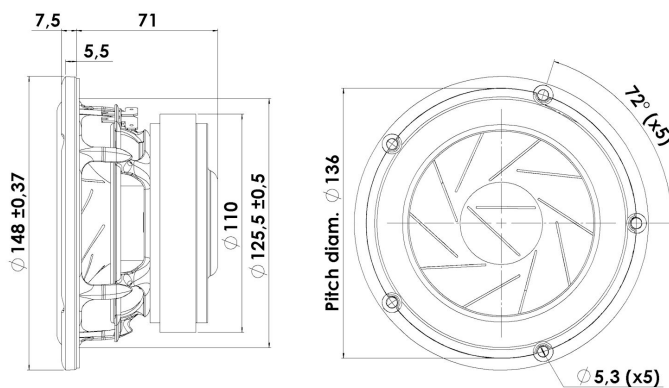

T-S Parameters:

Resonance frequency [fs]	42 Hz
Mechanical Q factor [Qms]	4.8
Electrical Q factor [Qes]	0.28
Total Q factor [Qts]	0.27
Force factor [Bl]	6 Tm
Mechanical resistance [Rms]	0.6 kg/s
Moving mass [Mms]	11 g
Compliance [Cms]	1.3 mm/N
Effective diaph. diameter [D]	110 mm
Effective piston area [Sd]	95 cm ²
Equivalent volume [Vas]	16 l
Sensitivity (2,83V/1m)	89.5 dB

Mechanical Data:

Voice coil diameter	38 mm
Voice coil height	11 mm
Voice coil layers	2
Gap height	5 mm
Linear excursion	± 3 mm
Max mech. excursion	± 8 mm
Unit weight	1.7 kg
Cabinet Displacement Volume	- l

Electrical Data:

Nominal impedance [Zn]	4 Ω
Minimum impedance [Zmin]	4.1 Ω
Maximum impedance [Zo]	53 Ω
DC resistance [Re]	3.5 Ω
Voice coil inductance [Le]	0.16 mH

Power Handling:

100h RMS noise test (IEC 18.4)	50 W
Long-term max power (IEC 18.2)	150 W
X-over:	None

Key Features:

- Excellent Midrange Reproduction
- Patented Symmetrical Drive motor design
- Sliced Cone (Controls Cone Breakups)
- Low-loss linear suspension
- High Output 89.5dB @ 2,83V
- Die cast Alu Chassis vented below spider

Recommendations (please see Tech Note):

- Operating frequency range: 65-7000 Hz
- Cabinet volume - closed box: Vbox=3.3 ltr, f(-3dB)=101 Hz
- Cabinet volume - vented box: Vbox=6 ltr, fb=58 Hz, f(-3dB)=64 Hz

